

TECHNICAL DATA

Three Phase Electric Motors - Cast Iron Frame
 HE30 250 M-2 IE2
 55 kW / 75 Cv
 2970 RPM

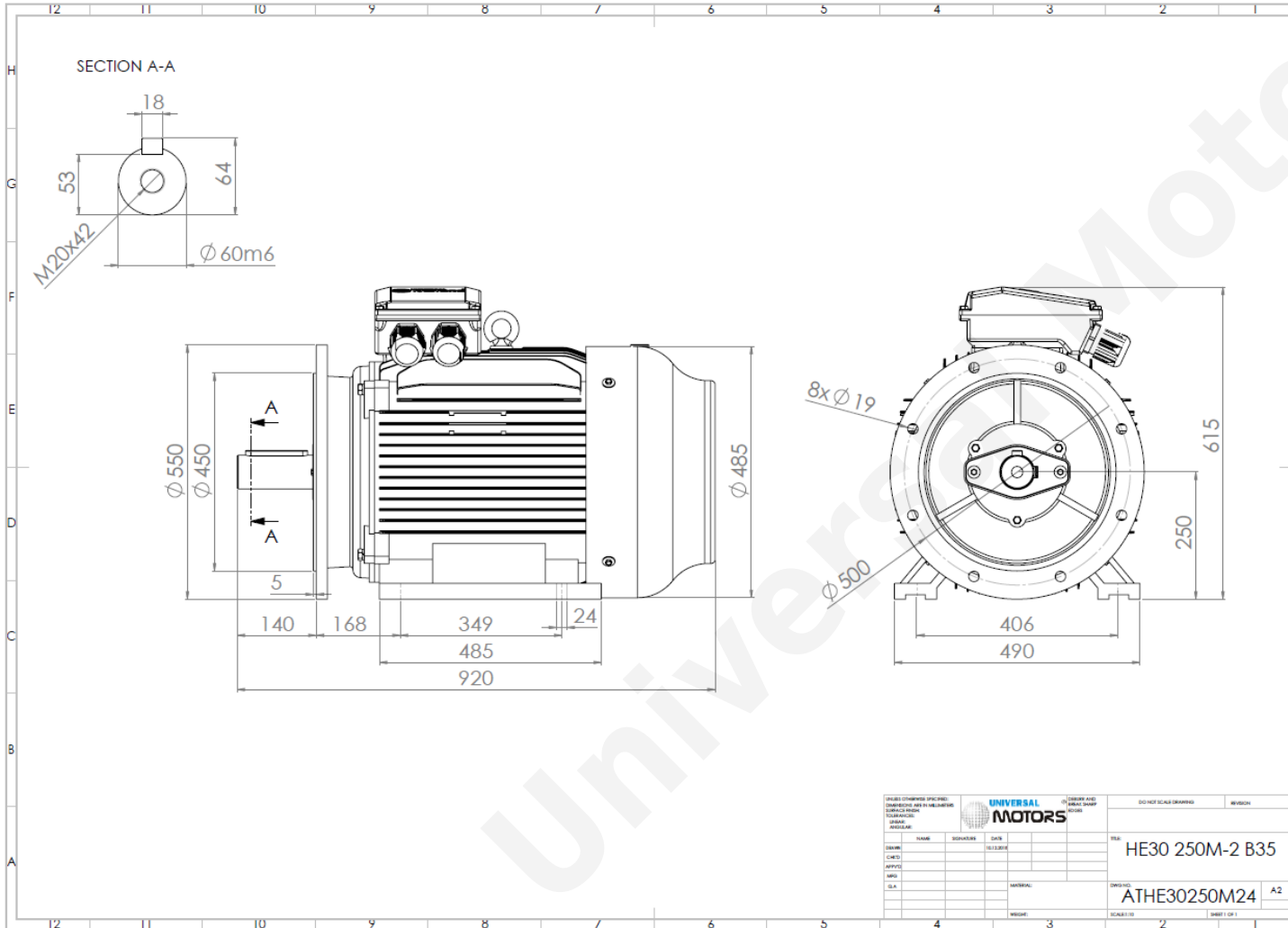

Motor type:	HE30 250 M-2 IE2
Output:	55 kW / 75 Cv
Speed (min ⁻¹):	2970 RPM
Frequency:	50 Hz
Voltage:	400 V
Current:	96.0 A
Power factor (Cos ϕ):	0.89
Poles:	2
Insulation class:	F
Temperature rise Class:	B
Efficiency 50%:	92.8 %
Efficiency 75%:	93.9 %
Efficiency 100%:	93.2 %
Torque:	177 N.m
Tstarting/Tnominal:	2.2
Istarting/Inominal:	7.6
Tmaximum/Tnominal:	2.3
Noise:	78 Db(A)
Weight:	387 Kg
Bearing DE:	6314 C3
Bearing NDE:	6314 C3

Regime - S1

Altitude - 1000m

Environment Temperature - 40°C

CONTACTS:

UNIVERSAL MOTORS Tel: +351 252 299 080
 Rua de São Brás,745 Fax: +351 252 299 089
 4480-782 VILA DO CONDE Mail: geral@universalmotors.pt

* References applied only in the UK